

The Founding

Stage Plot & Input List

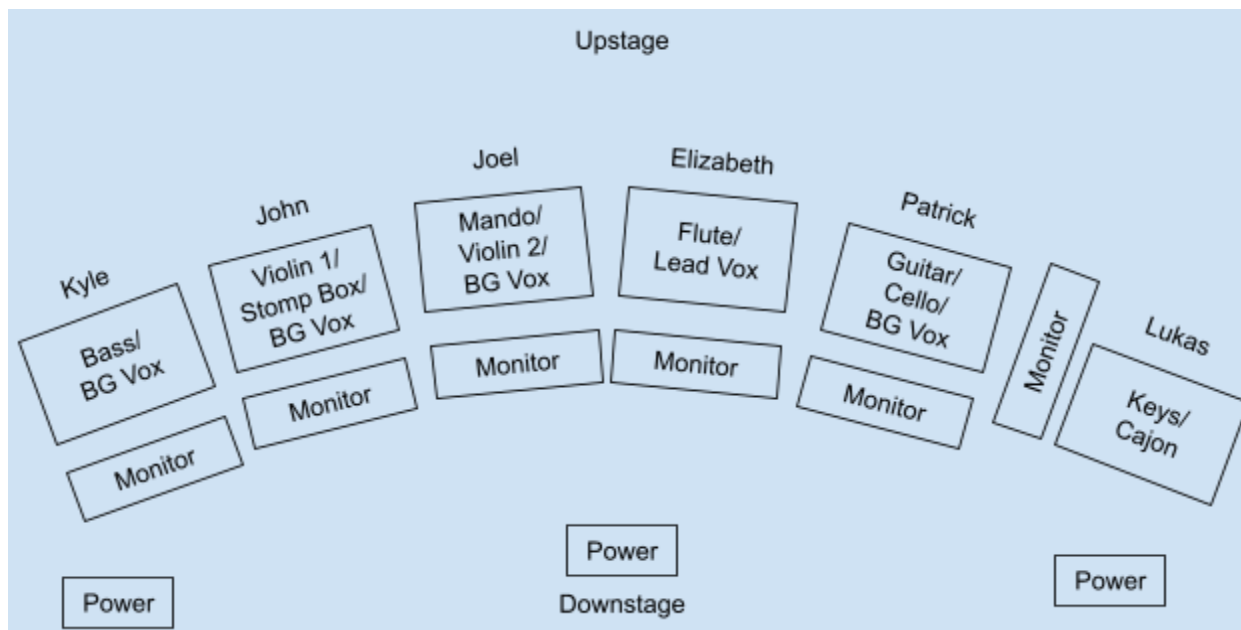

Stage placement reflects ideal scenario. 6 monitors and at least 4 mixes preferred if possible.

INPUTS

INPUT TYPE

1. Violin 1	Venue D.I. (Provided by Band)
2. Mandolin	Venue D.I. (Provided by Band)
3. Violin 2	D.I.
4. Guitar	D.I.
5. Upright Bass	D.I.
6. Keyboard (Mono)	D.I.
7. Stomp Box	D.I.
8. Cello	MIC (Minimum SM57), Short Boom Stand
9. Cajon	MIC (Minimum SM57), Short Boom Stand
10. Flute & Lead Vox	MIC (Minimum SM58)
11. John (BG Vox)	MIC (Minimum SM58)
12. Joel (BG Vox)	MIC (Minimum SM58)
13. Kyle (BG Vox)	MIC (Minimum SM58)
14. Patrick (BG Vox)	MIC (Minimum SM58)

*The Founding Equipment (If Needed): (4) Radial Pro D2, (2) SM58, (2) Blue Encore 200, (4) Boom Stands. Please contact band at thefoundingband@gmail.com (or John Robey at 517-402-0182) at least (5) days prior to performance date if any listed equipment is needed, or if you have any equipment logistics questions.